



# Mass/Blend<sup>®</sup>

## GENERATION 3

# The 15 Minute Chalk Talk

US Patent 6,186,193 B1  
Additional Patents Pending

# Who We Are

- A 27 year old technology pioneer in the field of liquid products blending and filling since 1980.
- A custom engineering house that solves problems for customers.
- A trusted and valued technology resource for customers.
- A company that continues to raise the bar in terms of technology.



# Who Our Customers Are



- Fortune “1000” companies. Companies, worldwide, in the personal care products industries, in the pharmaceutical industry, in the chemical processing and food processing industries, in the paints and pigments industries, and in the household, general industrial, and oil products industries.
- Companies who understand the need for the highest quality machinery and service.

# What We Do

- Pioneer a constant stream of “cutting-edge” innovations that include:
  - The first “rotary pump + servo” liquid filling methodology, 1980.
  - The first “Coriolis mass meter based” net weight liquid filler “family”, 1996. (US Patent 5,996,650)
  - The first “true digital” continuous stream blending system “family”, 1996. (US Patent 6,186,193 B1)

# What We Do

- Manufacture liquid blending and filling systems that are recognized as the gold standard of the industry :
  - NET/MASS<sup>®</sup> Coriolis mass flow meter based net weight liquid filling systems.
  - PRO/FILL<sup>®</sup> volumetric rotary motion positive displacement liquid filling systems.
  - MASS/BLEND<sup>®</sup> Continuous Stream Digital Blending Systems.
  - Oden MICRO/DOSE<sup>®</sup> High Speed LPD Systems.

# What Sets Us Apart From The Competition

- The “world standard” for filling machine versatility.
- The “world standard” for blending machine flexibility.
- Modular machine construction - expandable by design.
- Electronic machine configuration: the fly by wire software is the machine.
- Unrivaled product range - we sell to all technical and market segments.
- Technology, technology, technology.





# Why Our Customers Are Our Best References

- We set the standard for ethics, honesty, integrity, and customer service, around the globe.
- We give our customers the power of our technology.
- Nearly 60% of new machine business each year comes from our existing customers.

# Oden's Mass/Blend<sup>®</sup> Products



# What Must A Successful Continuous Stream Blending System Provide?

## **IT MUST:**

- 1. Be accurate.
- 2. Be reliable.
- 3. Have no penalty stop-start.
- 4. Operate from zero to max flow rate.
- 5. Operate a large range of formula ratios.
- 6. Operate across a large range of viscosities.
- 7. Not be temperamental or cranky.
- 8. Provide gobs of data (SPC).
- 9. Have multiple layers of performance validation and verification.
- 10. Have low system volume.
- 11. Be CIP friendly.

# What Makes Oden's Continuous Stream Blending Systems Different?

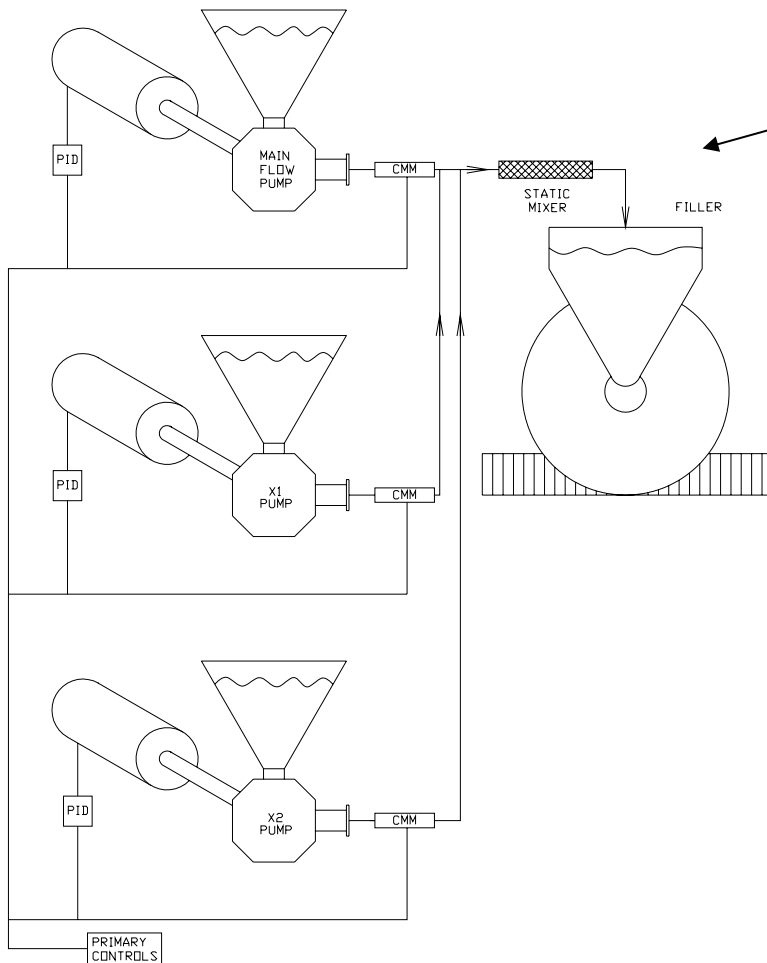

**WE DON'T DO THIS!**

## **THE TYPICAL DESIGN**

- Hydraulic PID loop based.
- Every flow stream is “visible” to every other.
- A series of interlocking tightropes - a balancing act.
- A forced solution.
- Each performance adjustment on a given stream is directly contradictory to the setpoints of every other stream.
- Outcomes range from disaster to “tamed” within a narrow operating range, with poor accuracy, much waste.
- This design needs a babysitter, along with a cop.

# What Makes Oden's Continuous Stream Blending Systems Different?

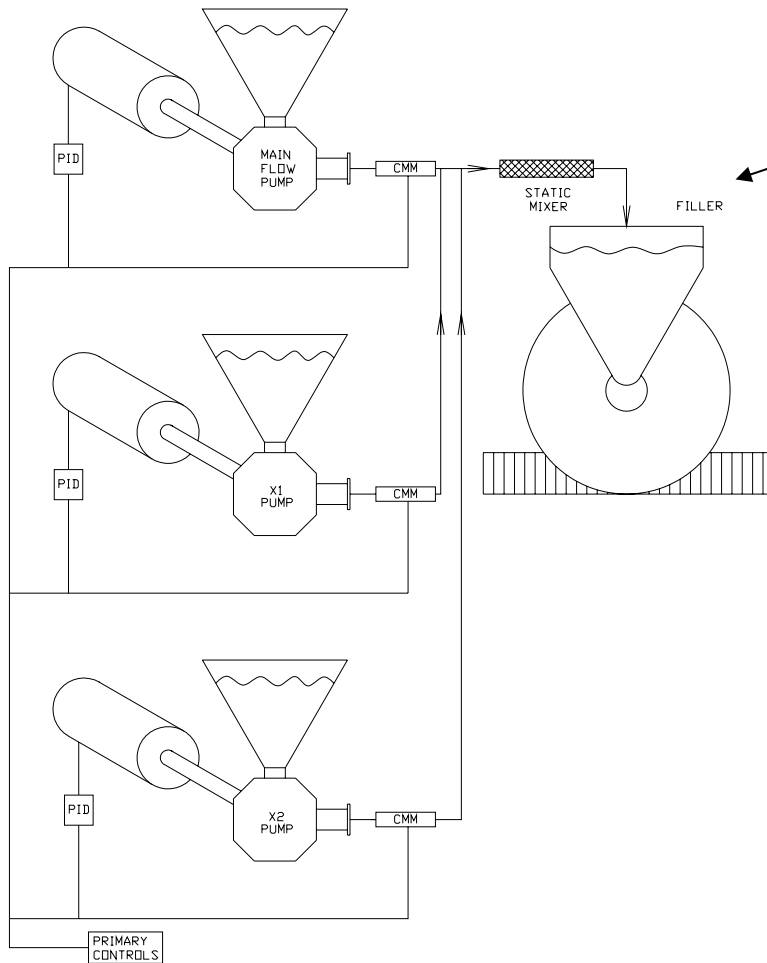

**WE DON'T DO THIS!**

## **THE TYPICAL DESIGN**

- Hydraulic PID loop based.
- Every flow stream is “visible” to every other.
- A series of interlocking tightropes - a balancing act.
- A forced solution.
- Each performance adjustment on a given stream is directly contradictory to the setpoints of every other stream.
- Outcomes range from disaster to “tamed” within a narrow operating range, with poor accuracy, much waste.
- This design needs a babysitter, along with a cop.

# What Makes Oden's Continuous Stream Blending Systems Different?

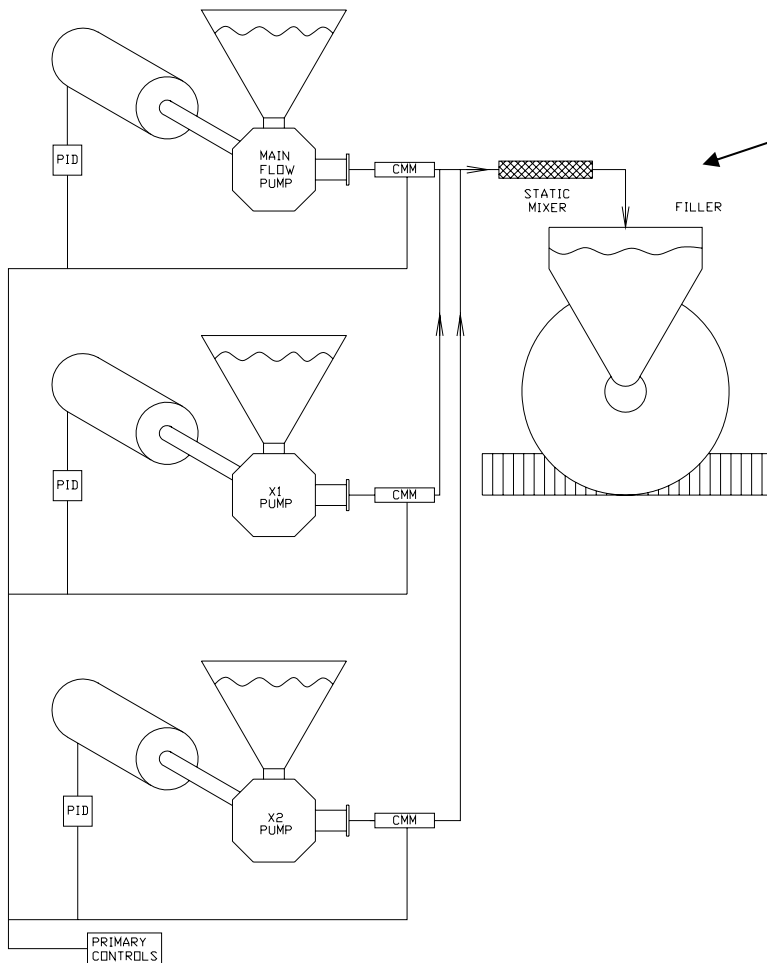

**WE DON'T DO THIS!**

## **THE TYPICAL DESIGN**

- Hydraulic PID loop based.
- Every flow stream is “visible” to every other.
- A series of interlocking tightropes - a balancing act.
- A forced solution.
- Each performance adjustment on a given stream is directly contradictory to the setpoints of every other stream.
- Outcomes range from disaster to “tamed” within a narrow operating range, with poor accuracy, much waste.
- This design needs a babysitter, along with a cop.

# What Makes Oden's Continuous Stream Blending Systems Different?

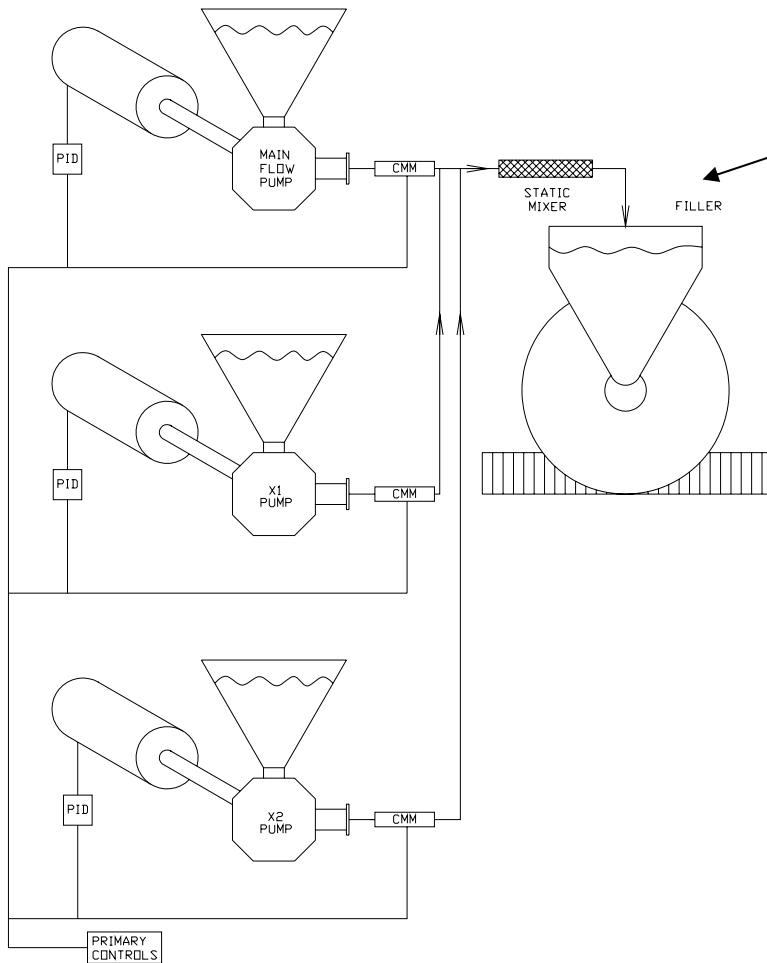

**WE DON'T DO THIS!**

## **THE TYPICAL DESIGN**

- Hydraulic PID loop based.
- Every flow stream is “visible” to every other.
- A series of interlocking tightropes - a balancing act.
- A forced solution.
- Each performance adjustment on a given stream is directly contradictory to the setpoints of every other stream.
- Outcomes range from disaster to “tamed” within a narrow operating range, with poor accuracy, much waste.
- This design needs a babysitter, along with a cop.

# What Makes Oden's Continuous Stream Blending Systems Different?

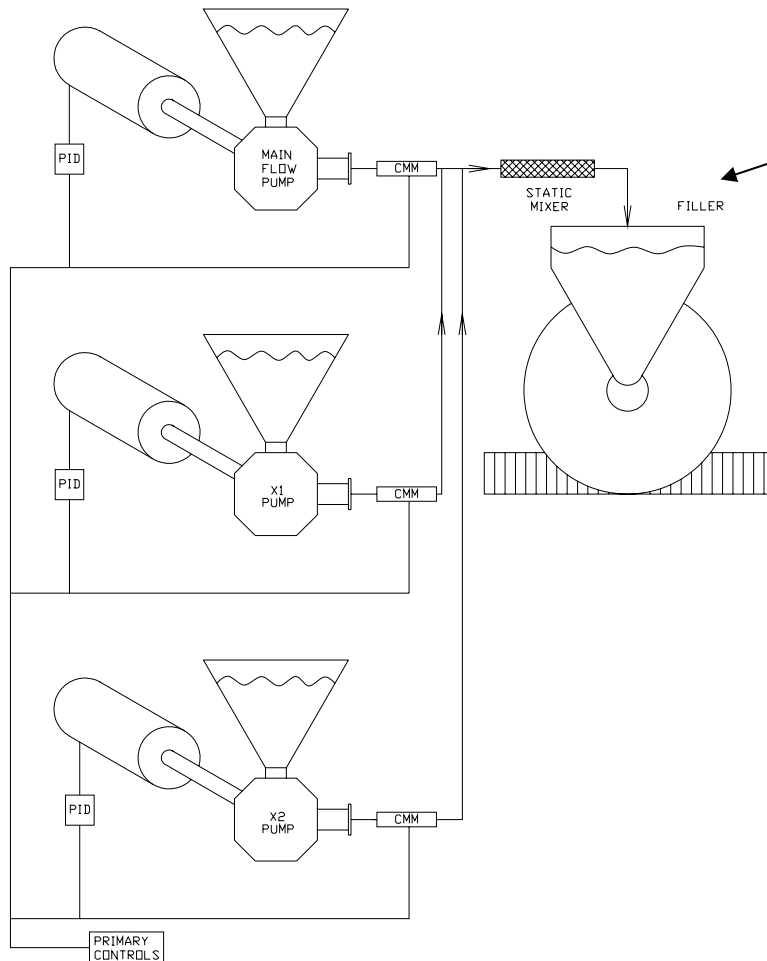

**WE DON'T DO THIS!**

## **THE TYPICAL DESIGN**

- Hydraulic PID loop based.
- Every flow stream is “visible” to every other.
- A series of interlocking tightropes - a balancing act.
- A forced solution.
- Each performance adjustment on a given stream is directly contradictory to the setpoints of every other stream.
- Outcomes range from disaster to “tamed” within a narrow operating range, with poor accuracy, much waste.
- This design needs a babysitter, along with a cop.

# What Makes Oden's Continuous Stream Blending Systems Different?

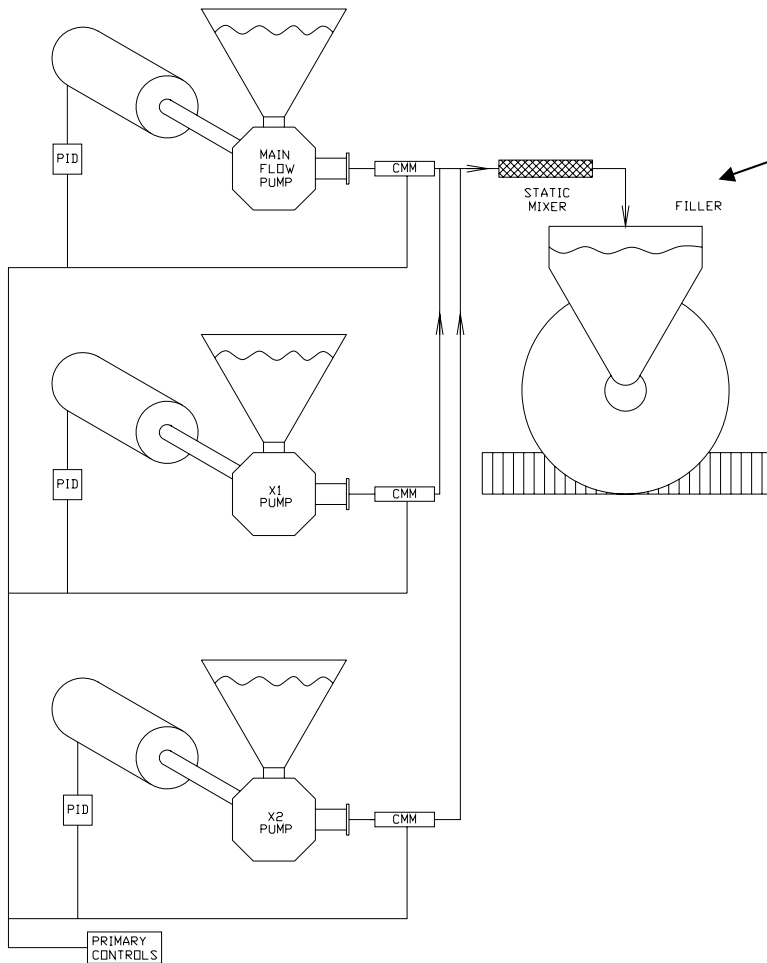

**WE DON'T DO THIS!**

## **THE TYPICAL DESIGN**

- Hydraulic PID loop based.
- Every flow stream is “visible” to every other.
- A series of interlocking tightropes - a balancing act.
- A forced solution.
- Each performance adjustment on a given stream is directly contradictory to the setpoints of every other stream.
- Outcomes range from disaster to “tamed” within a narrow operating range, with poor accuracy, much waste.
- This design needs a babysitter, along with a cop.

# What Makes Oden's Continuous Stream Blending Systems Different?

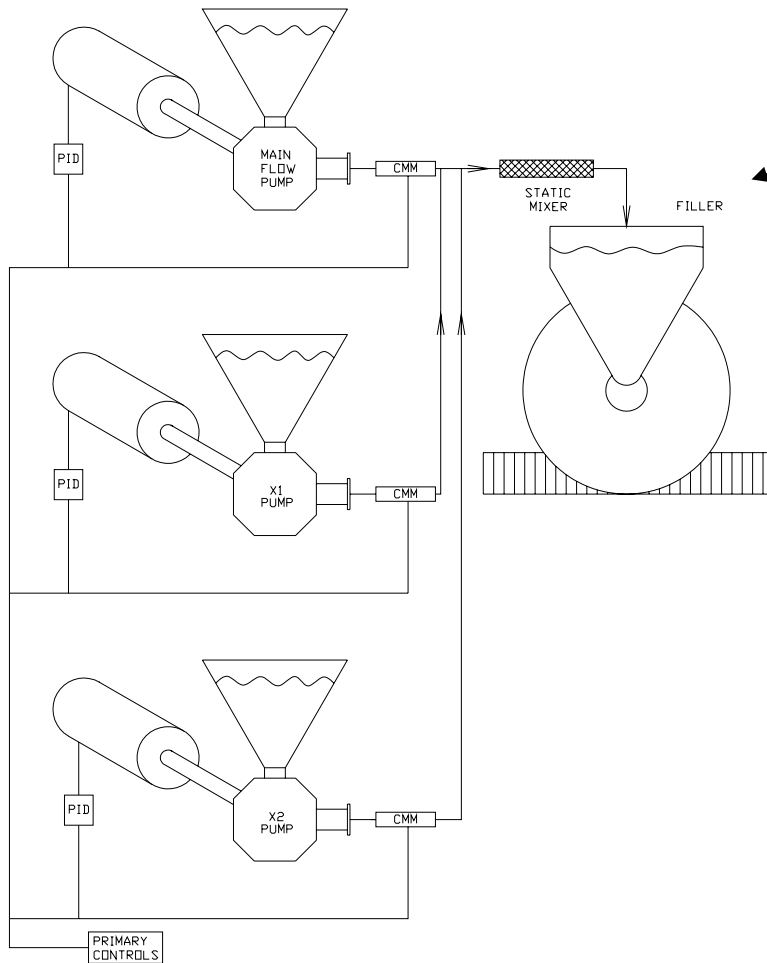

**WE DON'T DO THIS!**

## **THE TYPICAL DESIGN**

- Hydraulic PID loop based.
- Every flow stream is “visible” to every other.
- A series of interlocking tightropes - a balancing act.
- A forced solution.
- Each performance adjustment on a given stream is directly contradictory to the setpoints of every other stream.
- Outcomes range from disaster to “tamed” within a narrow operating range, with poor accuracy, much waste.
- This design needs a babysitter, along with a cop.

# What Makes Oden's Continuous Stream Blending Systems Different?

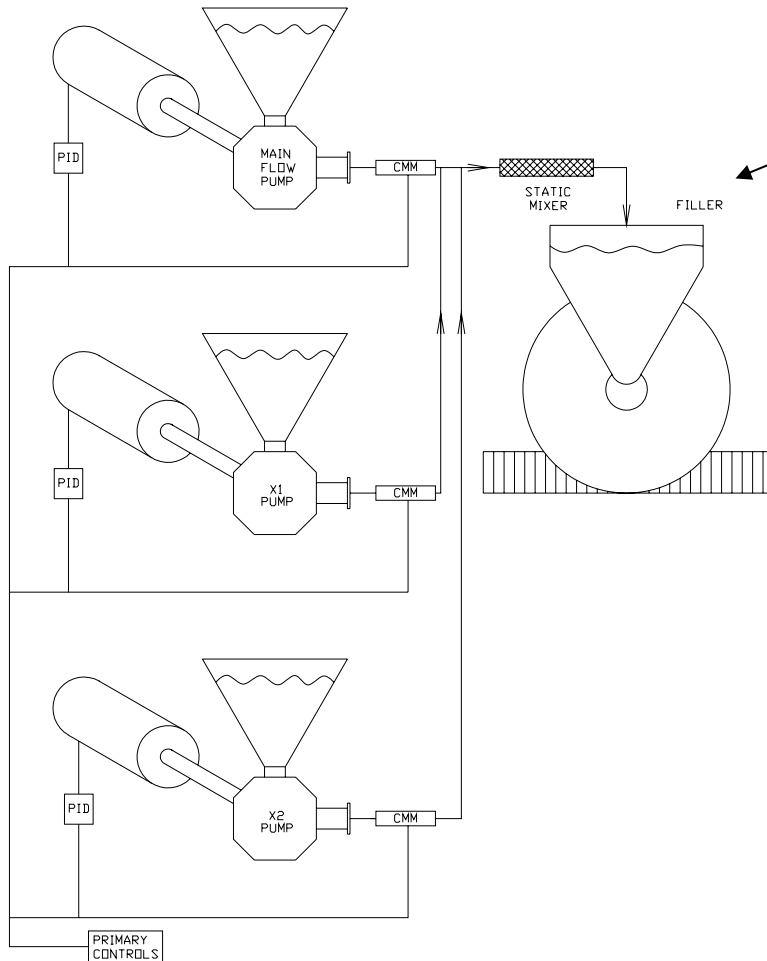

**WE DON'T DO THIS!**

## **THE TYPICAL DESIGN**

- Hydraulic PID loop based.
- Every flow stream is “visible” to every other.
- A series of interlocking tightropes - a balancing act.
- A forced solution.
- Each performance adjustment on a given stream is directly contradictory to the setpoints of every other stream.
- Outcomes range from disaster to “tamed” within a narrow operating range, with poor accuracy, much waste.
- This design needs a babysitter, along with a cop.

# What Works – What Does Oden Do?

## 3 Logical Steps To A Must Work System

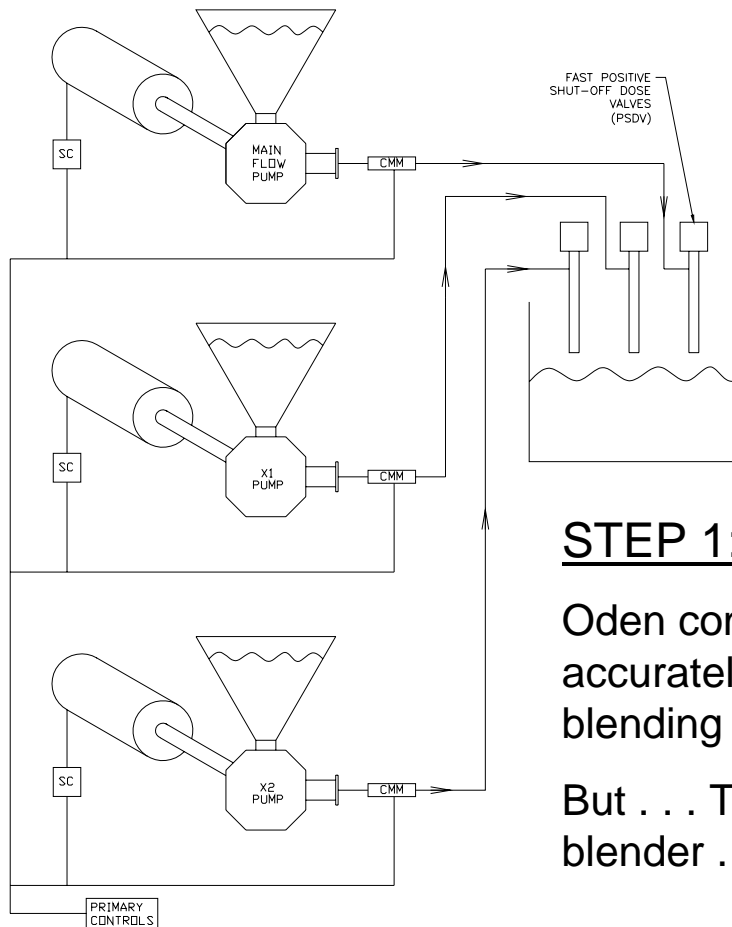

### STEP 1: SYNCHRONIZED DIGITAL FLOW

Oden combines G3 servo-pump mass meter fillers to accurately ratio dose product streams to a common blending location – on an on-off synchronized basis.

But . . . This looks like a spiffy batch system, not a blender . . .

# What Are The Favorable Attributes That Emerge From Step 1: Synchronized Digital Flow?

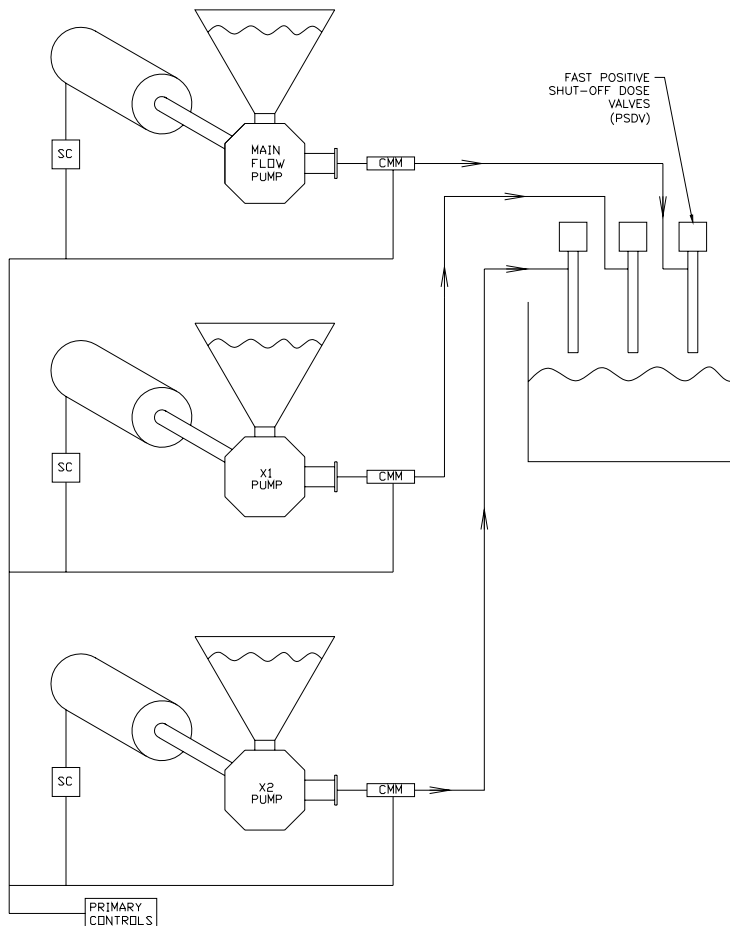

- Precisely synchronized flow - easy to do with servo-pump technology.
- Flow at a defined and low back pressure gives rational, predictable, rock solid ratio dose performance.
- Digital flow delivers exact mass ratios in a synchronized on/off mode. So - easy to check results and no cumulative error from ratio dose cycle to ratio dose cycle is possible.
- No stop-start problems.
- Direct empirical dose stream sampling for verification is easy.
- There is no cross talk between ratio streams – NONE!!!

# What Are The Favorable Attributes That Emerge From Step 1: Synchronized Digital Flow?

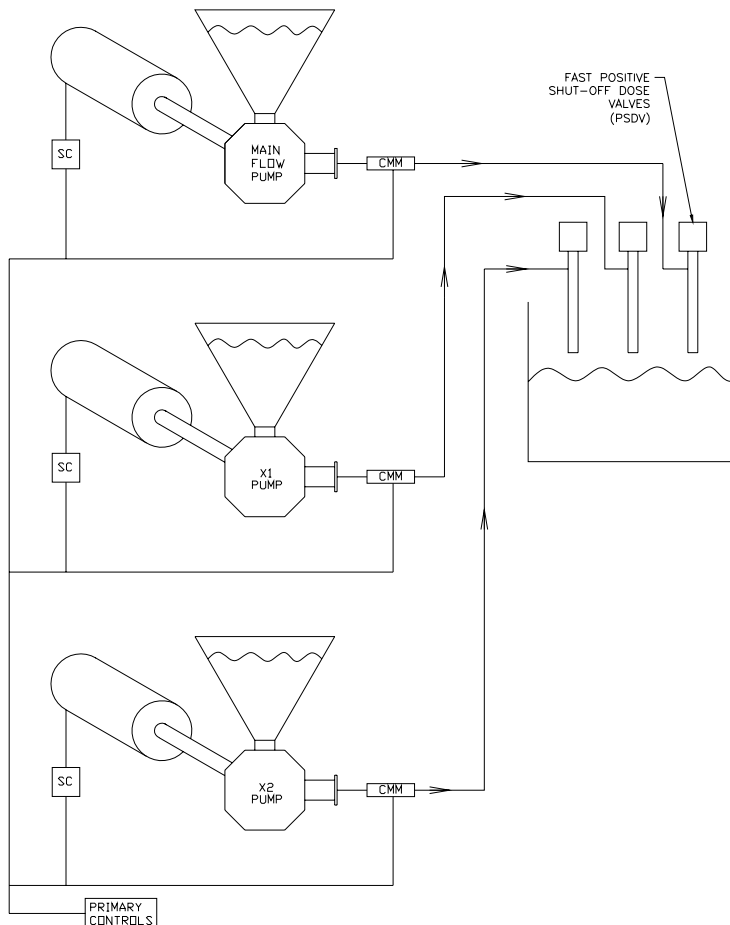

- Precisely synchronized flow - easy to do with servo-pump technology.
- Flow at a defined and low back pressure gives rational, predictable, rock solid ratio dose performance.
- Digital flow delivers exact mass ratios in a synchronized on/off mode. So - easy to check results and no cumulative error from ratio dose cycle to ratio dose cycle is possible.
- No stop-start problems.
- Direct empirical dose stream sampling for verification is easy.
- There is no cross talk between ratio streams – NONE!!!

# What Are The Favorable Attributes That Emerge From Step 1: Synchronized Digital Flow?

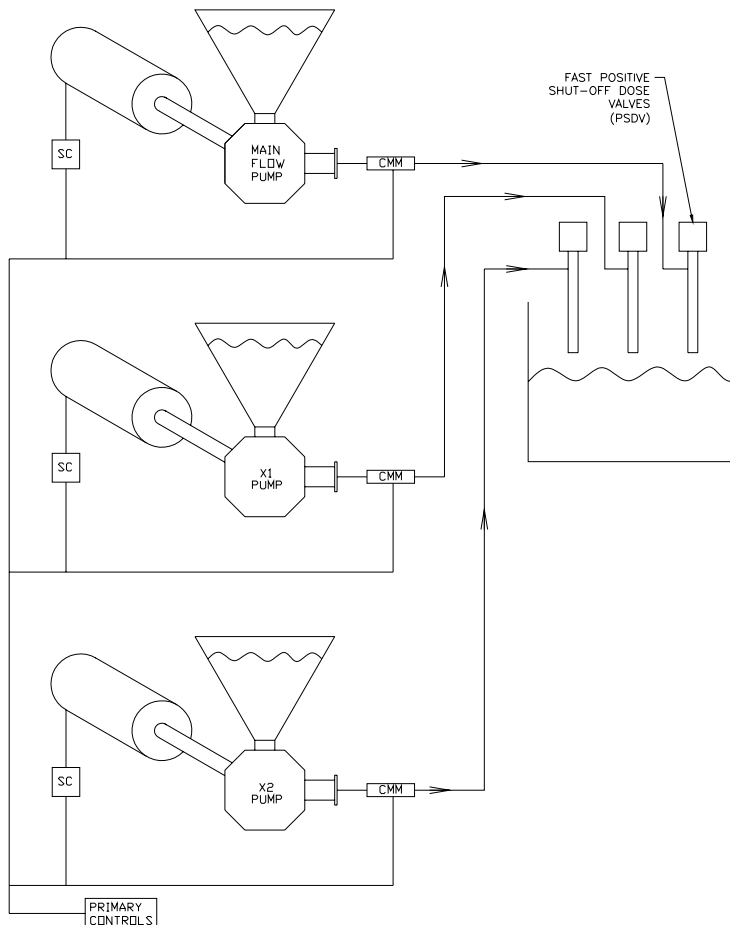

- Precisely synchronized flow - easy to do with servo-pump technology.
- Flow at a defined and low back pressure gives rational, predictable, rock solid ratio dose performance.
- Digital flow delivers exact mass ratios in a synchronized on/off mode. So - easy to check results and no cumulative error from ratio dose cycle to ratio dose cycle is possible.
- No stop-start problems.
- Direct empirical dose stream sampling for verification is easy.
- There is no cross talk between ratio streams – NONE!!!

# What Are The Favorable Attributes That Emerge From Step 1: Synchronized Digital Flow?

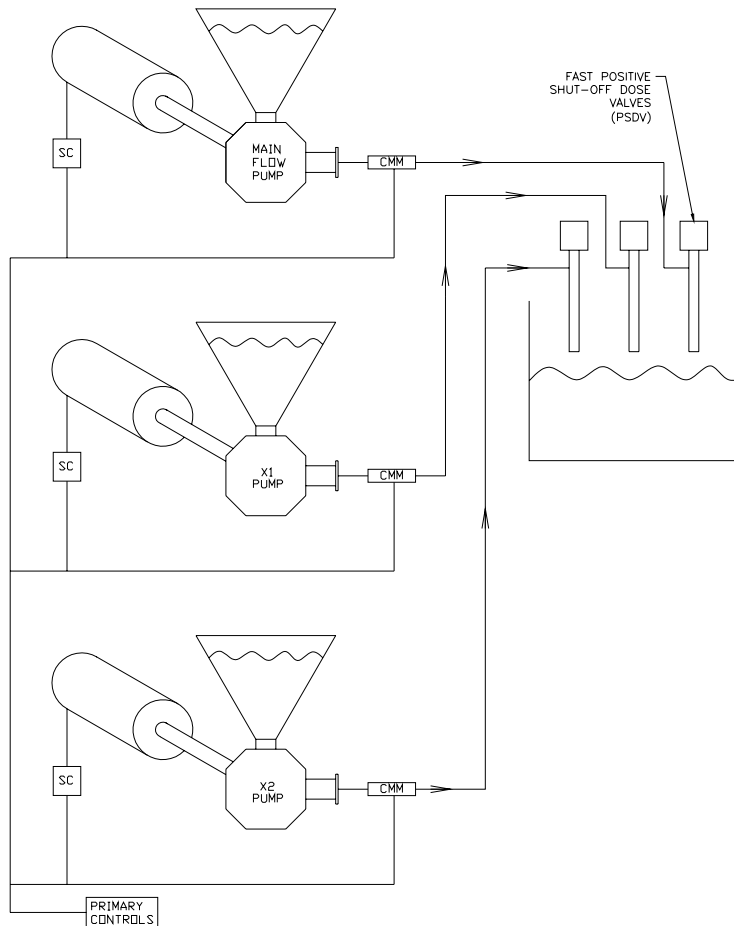

- Precisely synchronized flow - easy to do with servo-pump technology.
- Flow at a defined and low back pressure gives rational, predictable, rock solid ratio dose performance.
- Digital flow delivers exact mass ratios in a synchronized on/off mode. So - easy to check results and no cumulative error from ratio dose cycle to ratio dose cycle is possible.
- No stop-start problems.
- Direct empirical dose stream sampling for verification is easy.
- There is no cross talk between ratio streams – NONE!!!

# What Are The Favorable Attributes That Emerge From Step 1: Synchronized Digital Flow?

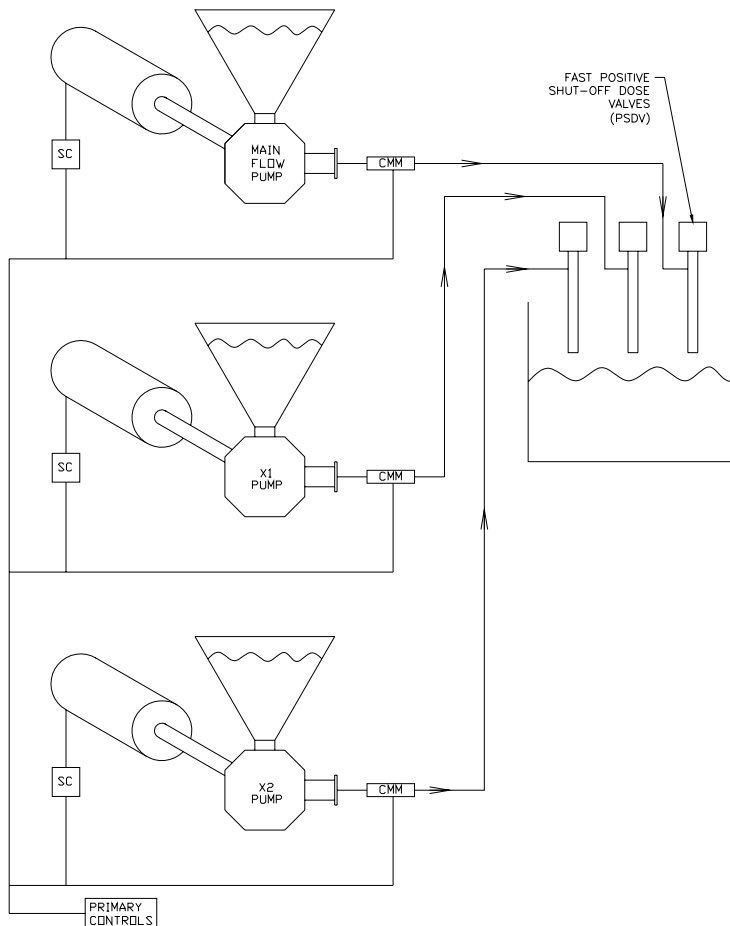

- Precisely synchronized flow - easy to do with servo-pump technology.
- Flow at a defined and low back pressure gives rational, predictable, rock solid ratio dose performance.
- Digital flow delivers exact mass ratios in a synchronized on/off mode. So - easy to check results and no cumulative error from ratio dose cycle to ratio dose cycle is possible.
- No stop-start problems.
- Direct empirical dose stream sampling for verification is easy.
- There is no cross talk between ratio streams – NONE!!!

# What Are The Favorable Attributes That Emerge From Step 1: Synchronized Digital Flow?

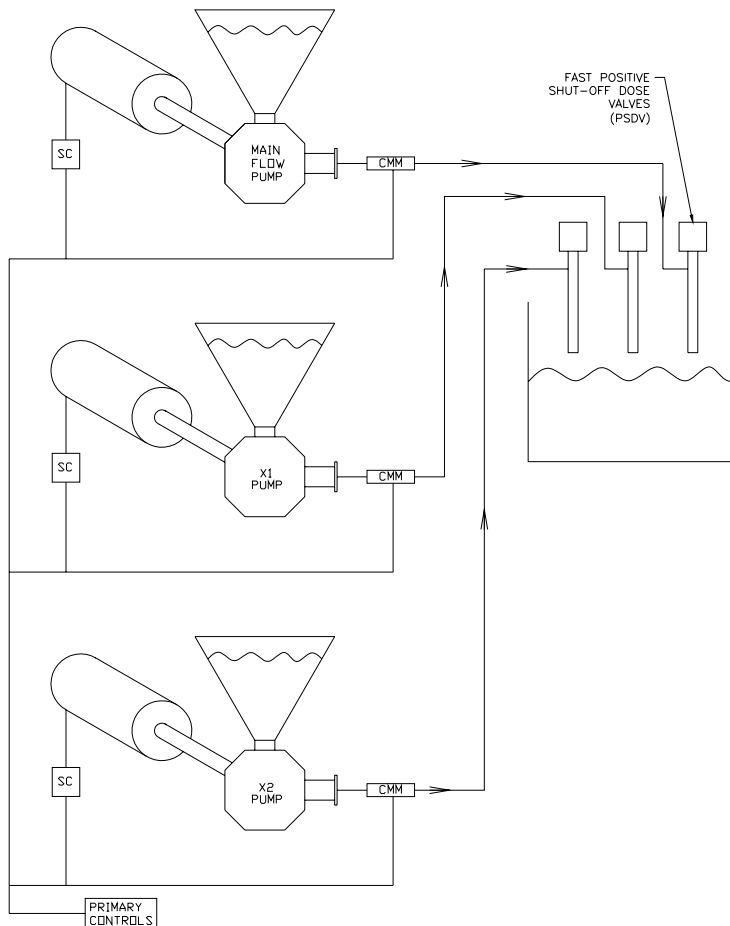

- Precisely synchronized flow - easy to do with servo-pump technology.
- Flow at a defined and low back pressure gives rational, predictable, rock solid ratio dose performance.
- Digital flow delivers exact mass ratios in a synchronized on/off mode. So - easy to check results and no cumulative error from ratio dose cycle to ratio dose cycle is possible.
- No stop-start problems.
- Direct empirical dose stream sampling for verification is easy.
- There is no cross talk between ratio streams – NONE!!!

# Step 1 (of 3): Synchronized Digital Flow

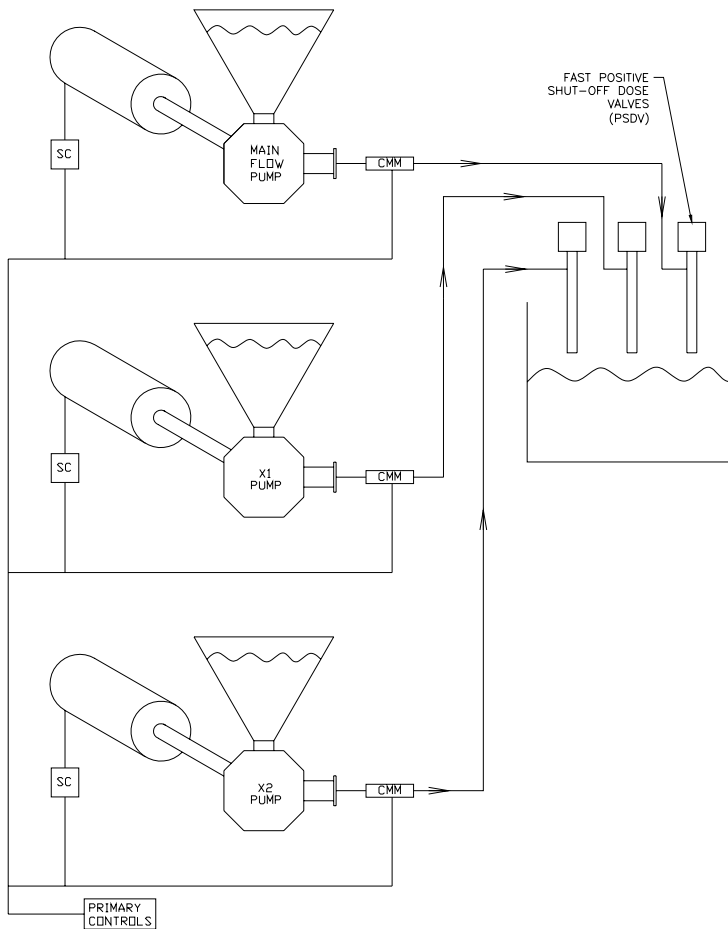

. . . but, this still looks like a spiffy batching system.

What's missing? Two Steps:

STEP 2: We need a blending and a mixing capability.

STEP 3: We need continuous flow - at the output of the system.

# Step 2: Add A Ratio Stream Mixing Capability

What are the favorable attributes of this arrangement?

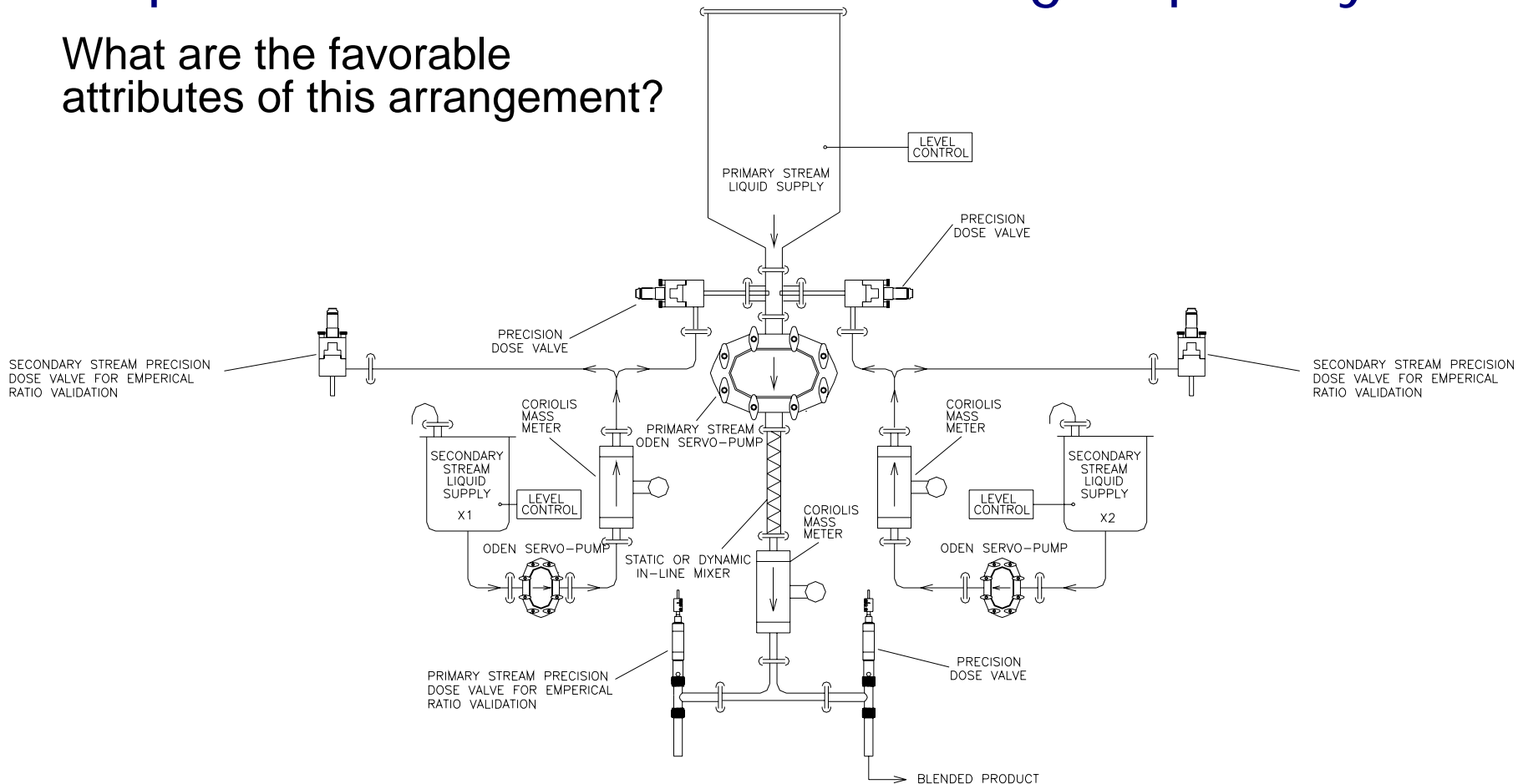

- Mixing and ratio combining are **DECOUPLED!!**

# Step 2: Add A Ratio Stream Mixing Capability

What are the favorable attributes of this arrangement?

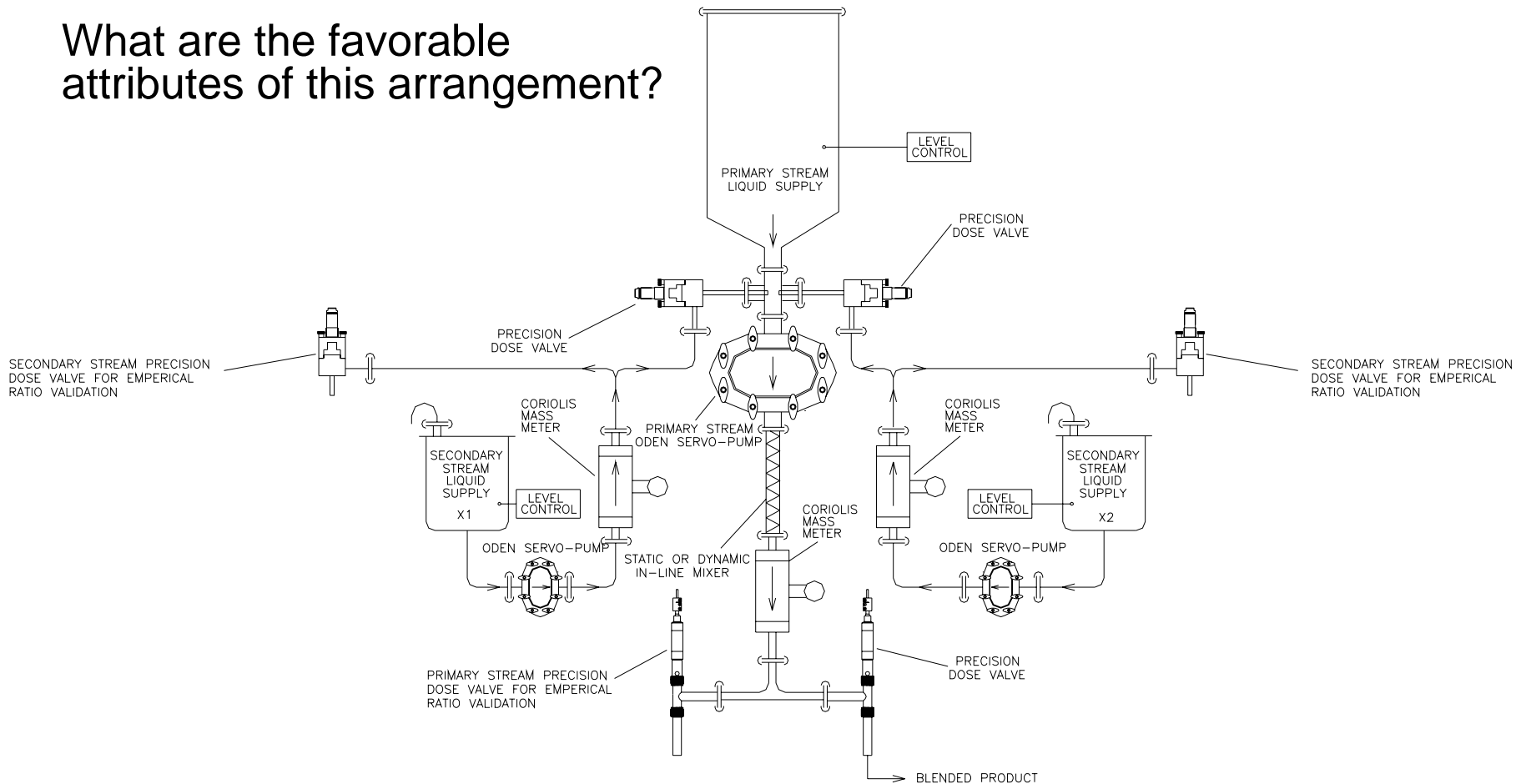

- Mixing engineering requirements are **INDEPENDENT** of ratio streams engineering requirements.

# Step 2: Add A Ratio Stream Mixing Capability

What are the favorable attributes of this arrangement?

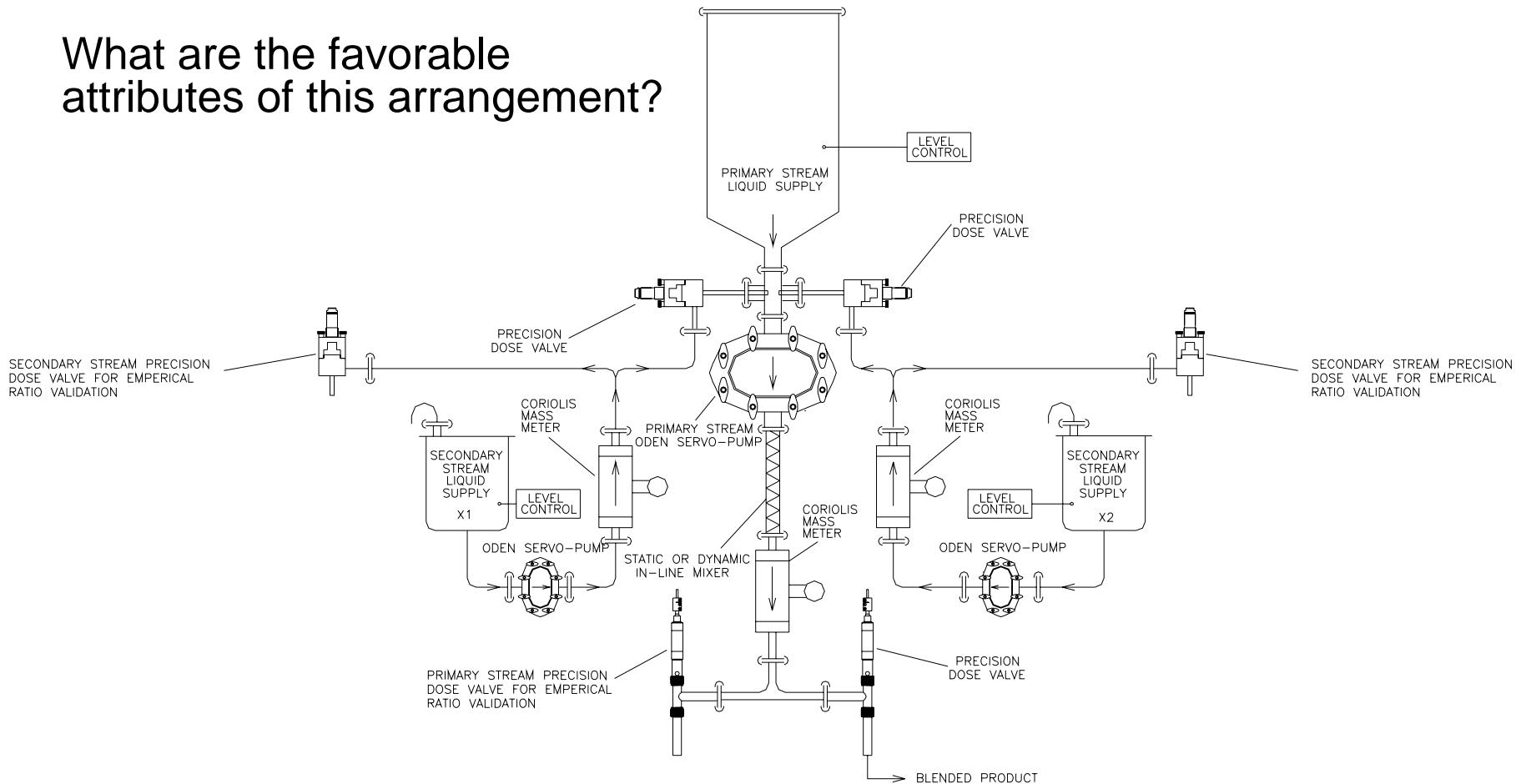

- High mixing back pressures have **NO BEARING** on ratio streams performance.

# Step 2: Add A Ratio Stream Mixing Capability

What are the favorable Attributes of this arrangement?

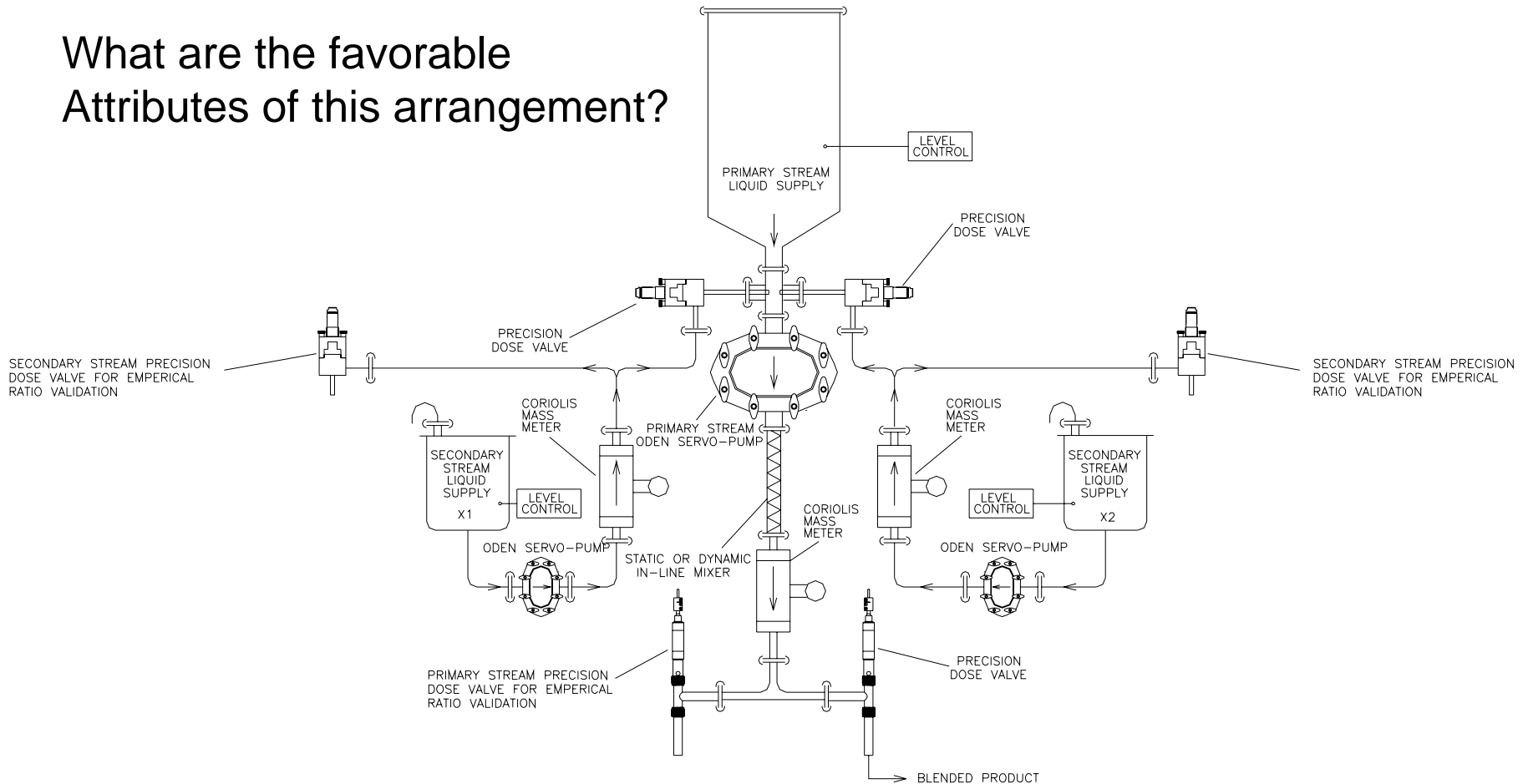

- The **DIVORCE** of streams ratio definition and mixing definition allows **NO COMPROMISES** in either subsystem.

# Step 2: Add A Ratio Stream Mixing Capability

What are the favorable attributes of this arrangement?

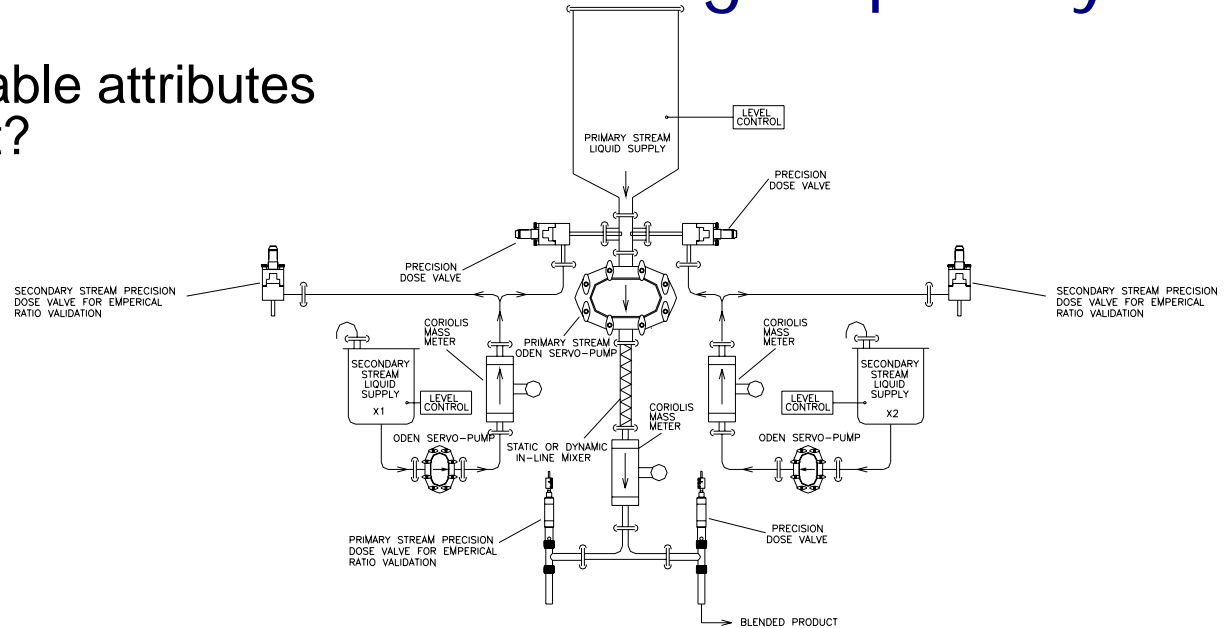

- Mixing and ratio combining are **DECOUPLED!!**
- Mixing engineering requirements are **INDEPENDENT** of ratio streams engineering requirements.
- High mixing back pressures have **NO BEARING** on ratio streams performance.
- The **DIVORCE** of streams ratio definition and mixing definition allows **NO COMPROMISES** in either subsystem.

# Where Are We?

- STEP 1: Synchronized digital flow.
- STEP 2: Mixing decoupled from streams ratio servo-pumps.

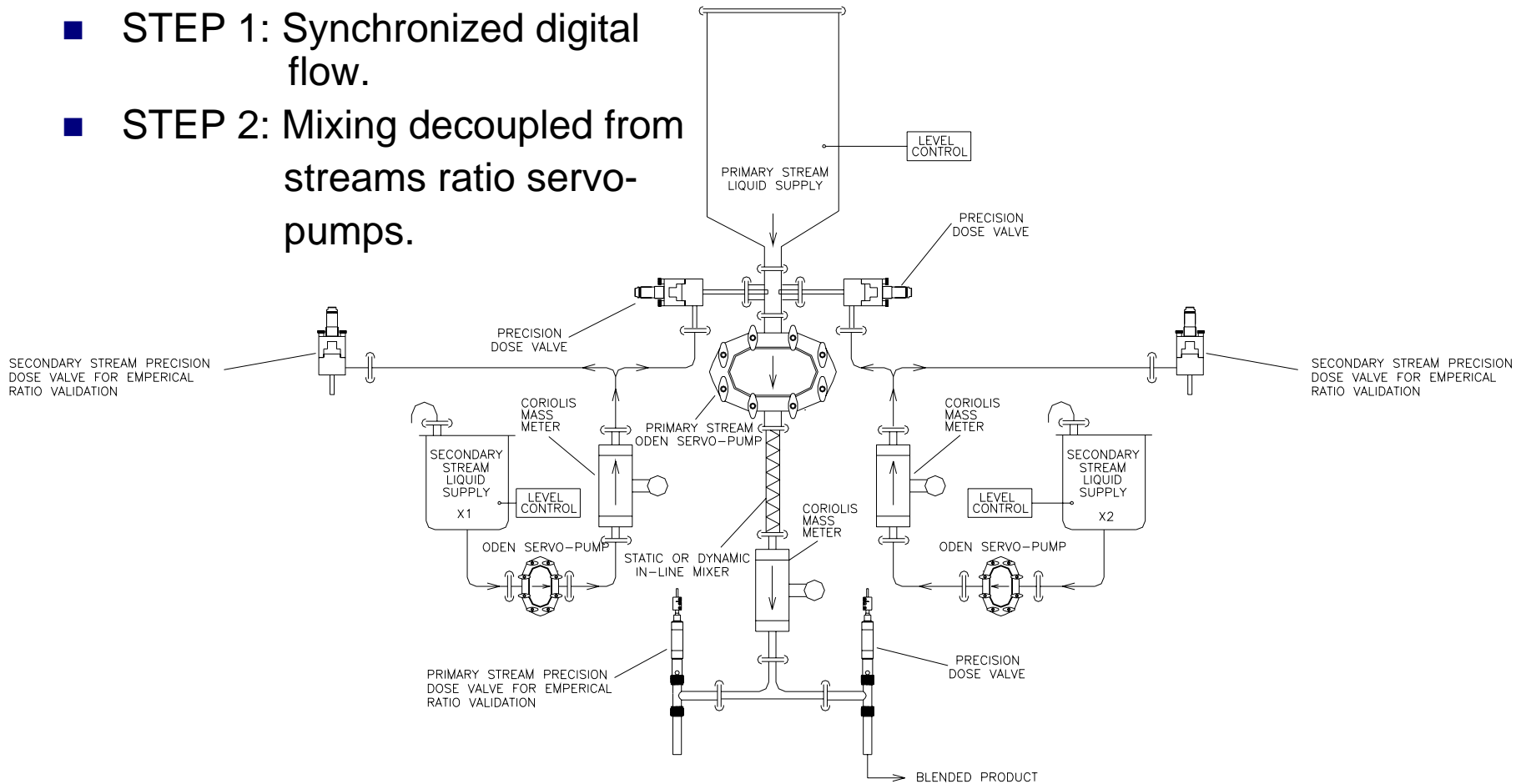

- BUT - WE NEED STEP 3:  
CONTINUOUS FLOW AT THE OUTPUT OF THE SYSTEM.

# Step 3: Add A Small Finished Product Tank

WHY DOES THIS COMPLETE THE DESIGN?

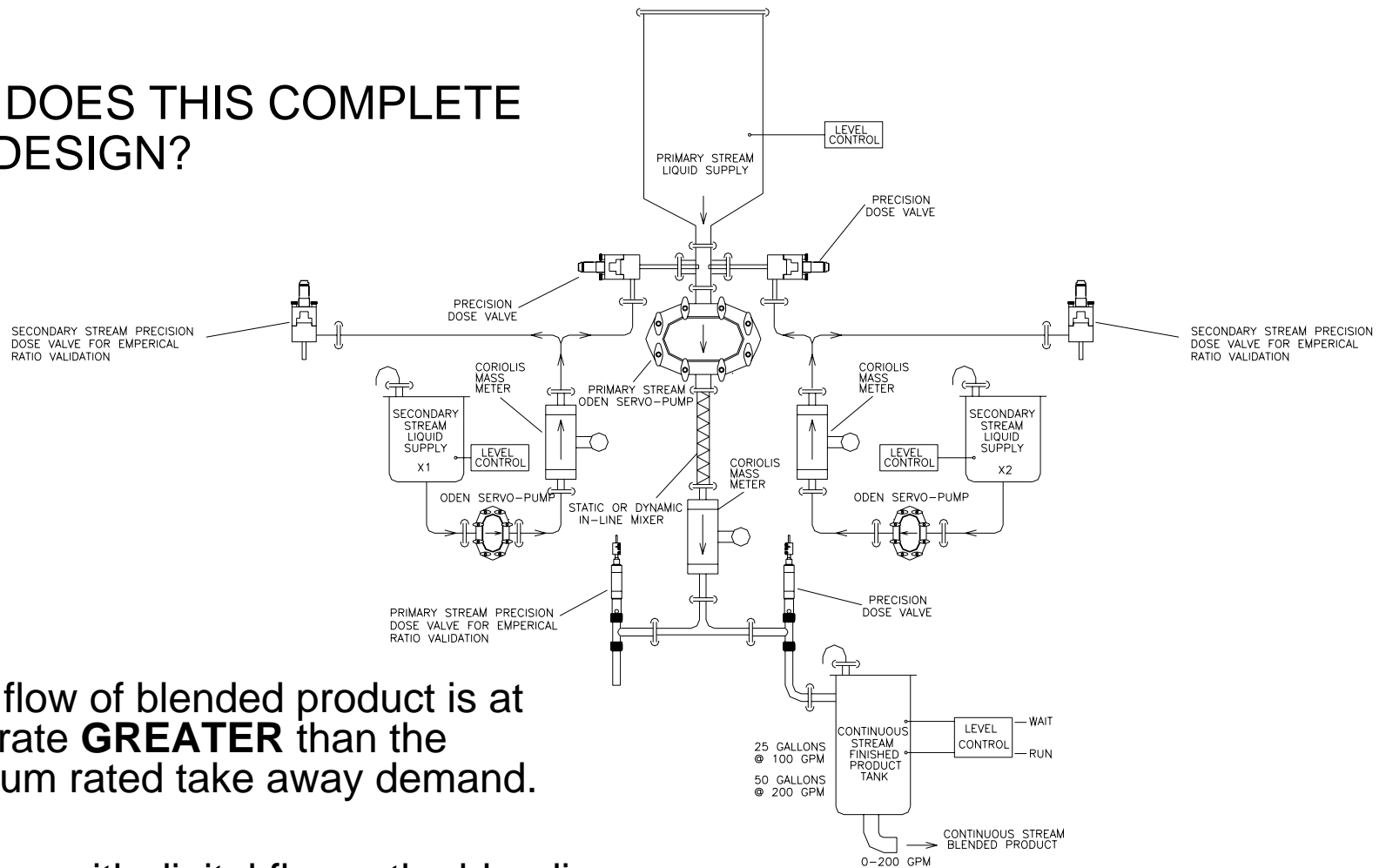

Digital flow of blended product is at a flow rate **GREATER** than the maximum rated take away demand.

So - even with digital flow – the blending system **CANNOT** be outpaced.

# What Are The Favorable Attributes of Step 3?

- Finished product is always available - at any demand flow up to max.
- The tank is designed to assure that flow from any blend cycle has a place to go.
- The tank is small - 25 gallons (beer keg) at 100 GPM; 50 gallons at 200 GPM.
- Control is absolutely **SIMPLE** - the filler drives. It is a very logical “ripple back” design.

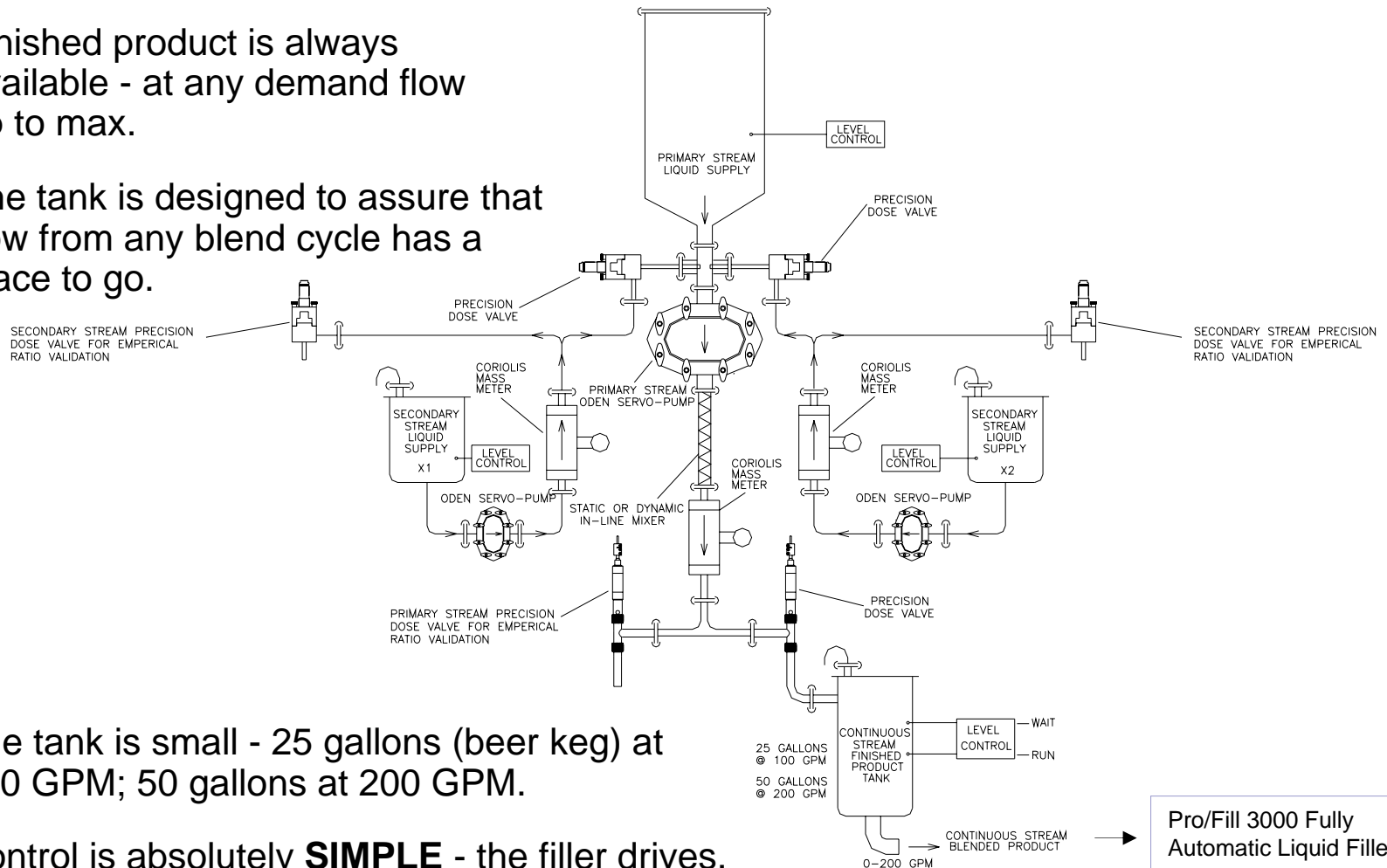

Pro/Fill 3000 Fully Automatic Liquid Filler

# The SMALL Finished Product Tank

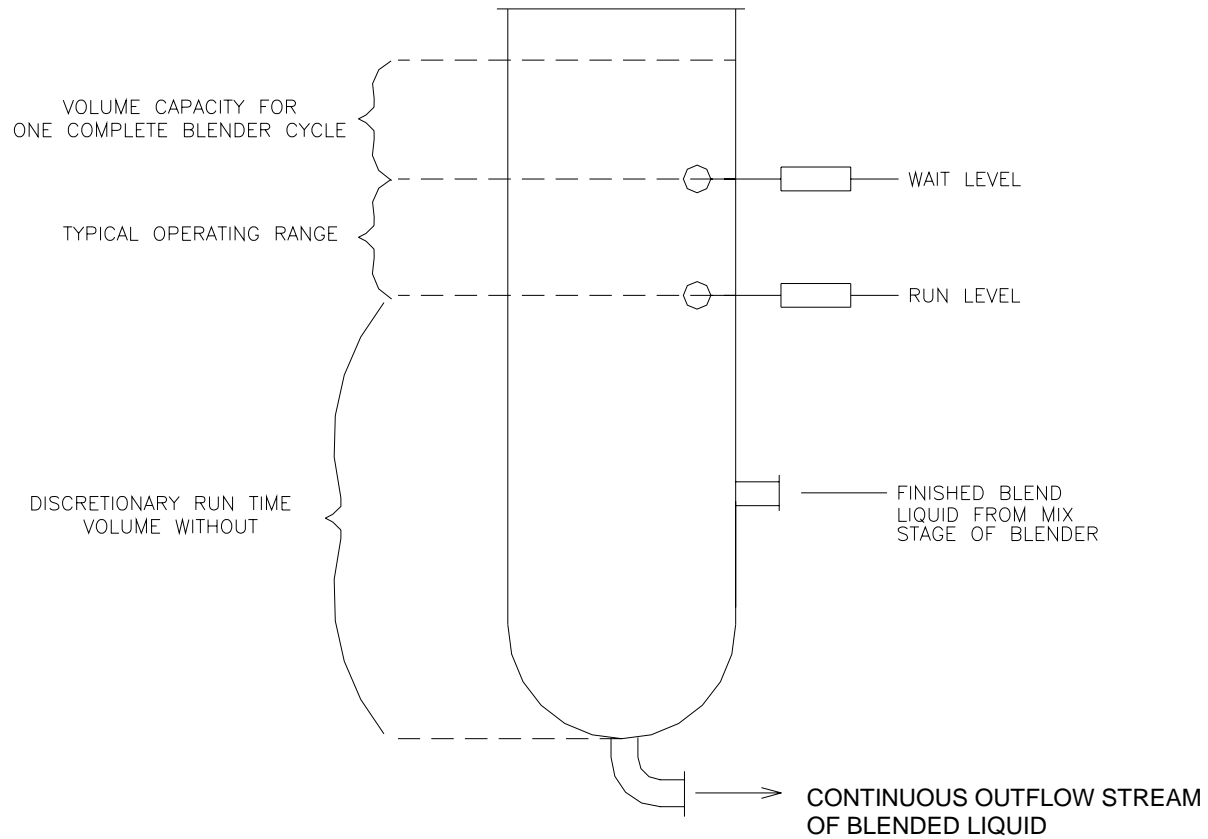

# Step 1 + Step 2 + Step 3

## STEP 1 + STEP 2 + STEP 3

A competent and completely sensible continuous stream blending system!!

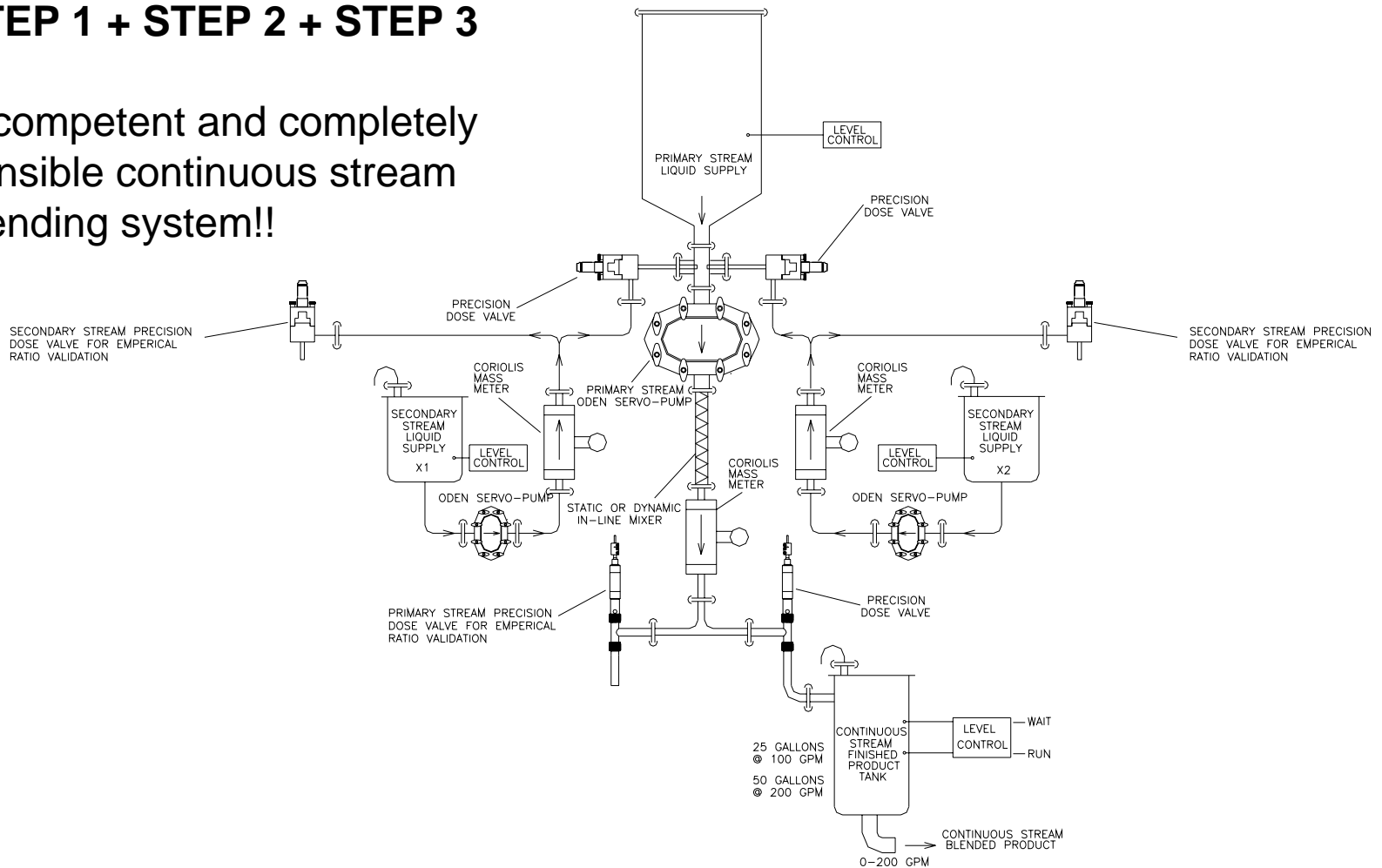

# -- A Final Thought --

Oden also makes continuous motion in-line fillers designed for late product additions at speeds to 1200 per minute.

~ NOW ~

Questions Please.



Oden Corporation © 2007

## **ODEN CORPORATION**

199 Fire Tower Drive, Tonawanda, NY 14150

800.658.3622 Toll Free Phone, 716.874.3000 Phone, 716.874.1589 Fax

[www.odencorp.com](http://www.odencorp.com), [sales@odencorp.com](mailto:sales@odencorp.com)